



35.10 Machine will not start:

❓ Confirm that the machine will not turn on – no motor running vs the cycle will not start

!***ALWAYS DISCONNECT POWER AND AIR WHEN CHECKING SWITCHES ***!

- Check the safety interlock switch (**See 35.11**)

- One of the most common reasons
- Switch is a failsafe and will not allow the machine to start if the lid is up

- Often becomes impacted with sawdust and will not function

- Open switch and blow out

- There have been several different types of switches used over time. Get brand name of switch:

- ABB – [E03300](#)
- IDEC – [E03340](#)
- Omron – [E03340](#) (IDEC and Omron have the same key.)
- Telemecanique – [E35001](#)
- Siemens – use [E03340](#) and request Omron type

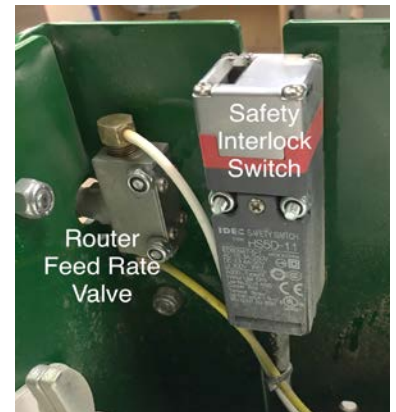

- Check the contacts at the back of the start and stop buttons ([E03000](#) Stop & [E35041](#) Start)

- See 35.12 & 35.13

- This is a continuity check – there should be a change in continuity when the buttons are depressed. Can be done with no power to the machine.

- Check the air pressure switch ([E35420](#)) (**See 35.14**)

- The air pressure switch is set at 40 psi at the factory. It can often go bad and be hard to diagnose.

- The easiest way to check is to bridge the two wires and see if the machine will turn on.

- We no longer use the air pressure switch. Customers can keep the bridge in place if they do not wish to replace.





TSM-35 Screw Pocket Machine Troubleshooting

- Check the transformer ([E35713](#))
 - ***** CAUTION: ONLY A QUALIFIED ELECTRICIAN SHOULD PERFORM THE FOLLOWING STEPS. POWER MUST BE SUPPLIED TO THE MACHINE TO CHECK THE TRANSFORMER. THIS PRODUCES A SHOCKING HAZZARD. DO NOT TOUCH THE CONTROL BOX COMPONENTS WITH ANYTHING OTHER THAN ELECTIRCAL TESTING PROBES. *****
 - There should be 230V 3ph or 480V 3ph going into the transformer (Check H1 (480V) or H2 (230V) AND H4 at top of transformer)
 - If no power into the transformer, check main power to the machine.
 - There should be 24V AC coming out of the transformer and entering the board at terminals 1 and 2
 - Check to make sure the fuse is intact ([E16224](#))
- *If all switches and transformer check out OK, then problem is with the contactor and/or overload.* ([E91024](#) Contactor / [E91827](#) 480V Overload / [E94060](#) 230V Overload / [E94061](#) Single phase overload)
 - Check for loose wires on Contactor and Overload
 - It is recommended to change both components. Currently the Sprecher & Schuh (S & S) brand we use will need both pieces to be changed, regardless if there is an old S & S in the machine. The new revision will not work with the old.
 - ******** Components from different manufacturers **cannot** be combined. ********



35.11 Test Safety Interlock Switch (NO)

- Disconnect power and air from the machine.
- Unplug the black wire on the pressure switch located in the control box just above the control board.
- Touch continuity tester to “A1” on the contactor and to the **black wire** that was removed from the pin on the pressure gauge.
- When lid is closed, the switch tester should read closed. When the lid is opened, the tester should read open.

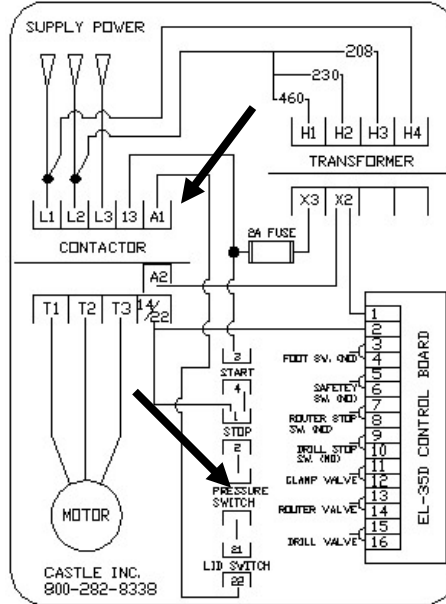
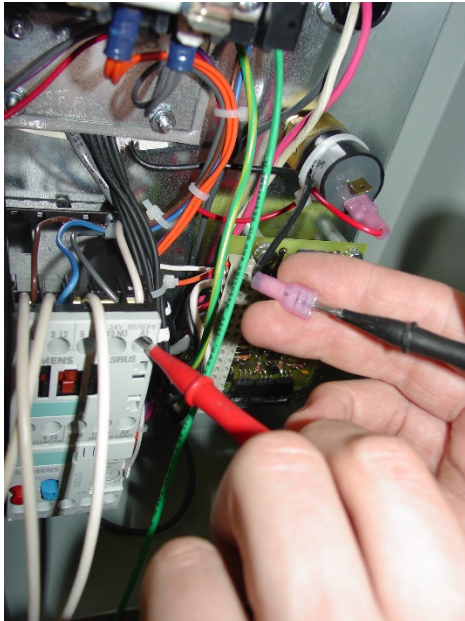

For Machines without the Air Pressure Switch:

- Disconnect power and air from the machine.
- Touch the continuity tested to “A1” on the contactor and pin #2 at the back of the stop switch.
- When the lid is closed, the switch tester should read closed. When the lid is opened, the tester should read open.

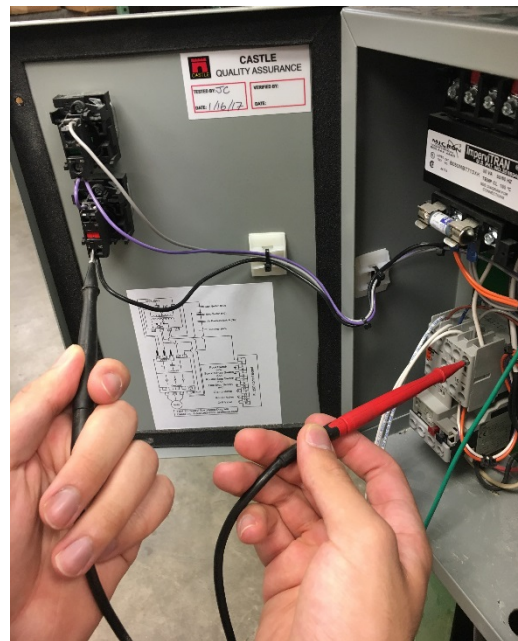



35.12 Test Start Switch (NO)

- Disconnect air and power from the machine
- Locate the contact block for the start switch located on the back side of the control box enclosure door.
- With a continuity tester, touch “-3” and “-4” terminals on the contact block.
- The switch should read (NO) at rest. When the start button is depressed the switch should close.

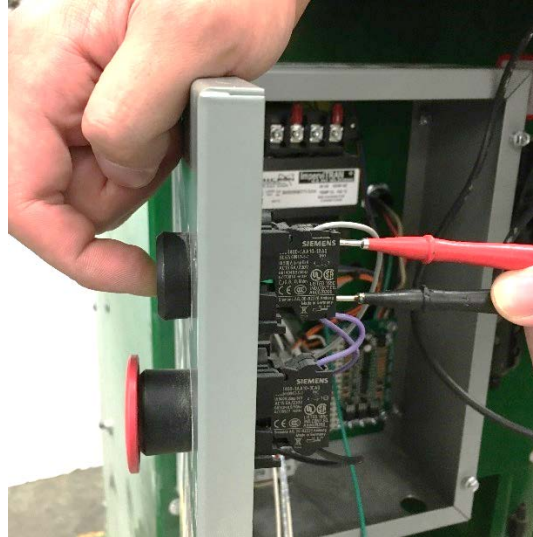

35.13 Test Stop Switch (NC)

- Disconnect air and power to the machine
- Locate the stop switch contact block on the back of the control box enclosure door.
- Use continuity tester and touch the pins to “-1” and “-2” on the stop switch contact block.
- When the stop switch is pushed in, the continuity tester should read open.
- When the switch is in the out position, the tester will read closed.

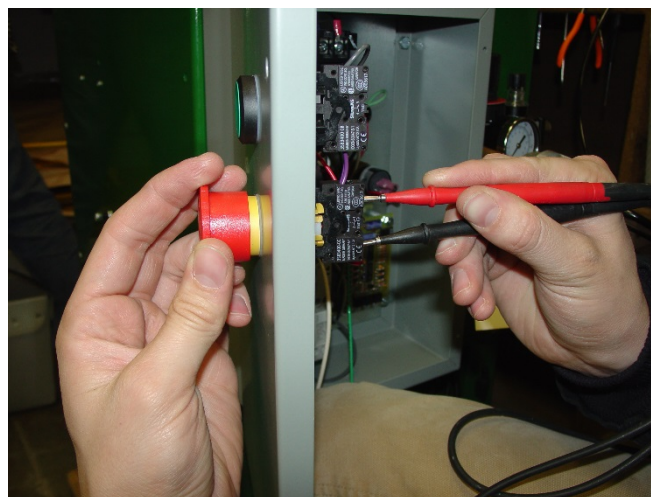



35.14 Test Air Pressure Switch (NO)

- Disconnect power and air from the machine.
- Unplug the black and red wires from the pressure switch
- Touch both of the pins on the pressure switch with the tester pins.
- The switch should read open with no air attached to the machine.
- Attach air to the machine and the switch should then read closed.

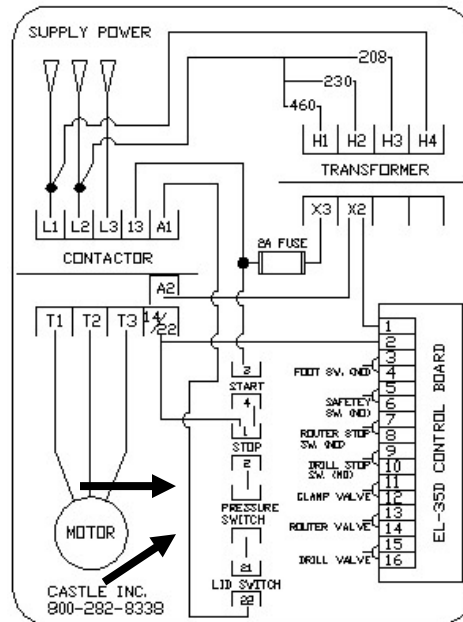
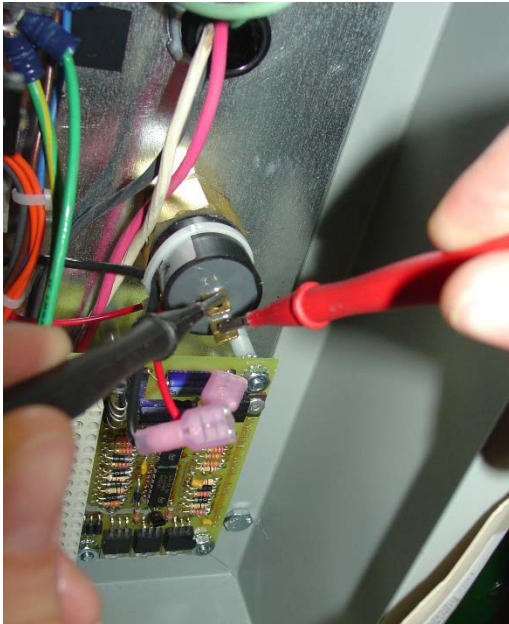

NOTE:

The air pressure switch is no longer used in the TSM-35. Its removal does not constitute a safety issue.

To bypass the switch in the system:

- Unplug the black and red wires from the pressure switch
- Cut the terminals off the wires, and strip the insulation
- Twist the ends together lightly
- Used a locknut to secure the wires

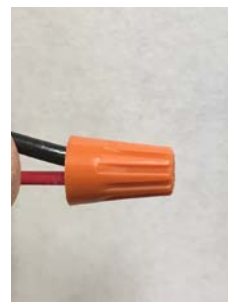



35.15 Motor starts, but cycle does not initiate:

- Confirm machine is receiving air.

!*** ALWAYS DISCONNECT POWER AND AIR WHEN CHECKING SWITCHES ***!

- Check the stock sense switch ([E10850](#)) and safety blade ([C35101](#))
 - Check switch for continuity: **(Also See 35.16)**
 - Remove one wire from the switch
 - Check for continuity at the switch by placing probes on the screws and moving the stock sense lever out of the way, then back
 - Check safety blade to make sure it swings and moves out of the way of the magnet when safety buttons are depressed
- Check the foot pedal switch ([E07041](#) Switch only / [E00491](#) Foot Pedal with Cord) **(Also See 35.17)**
 - Check for continuity change when depressed – can check at the switch or at terminals 3 & 4 on the terminal strip
 - Just switch can be changed. Buy from Castle or Grainger part 6X283
- Check to make sure there is power (24V AC) going into the board at terminals 1 & 2
 - ***** CAUTION: ONLY A QUALIFIED ELECTRICIAN SHOULD PERFORM THE FOLLOWING STEPS. POWER MUST BE SUPPLIED TO THE MACHINE TO CHECK THE TRANSFORMER AND CONTROL BOARD. THIS PRODUCES A SHOCKING HAZZARD. DO NOT TOUCH THE CONTROL BOX COMPONENTS WITH ANYTHING OTHER THAN ELECTIRCAL TESTING PROBES. *****
 - Check the transformer if no power ([E35713](#))
 - There should be 230V 3ph or 480V 3ph going into the transformer (Check H1 (480V) or H2 (230V) AND H4 at top of transformer)
 - If no power into the transformer, check main power to the machine
 - There should be 24V AC coming out of the transformer and entering the board at terminals 1 and 2
 - Check to make sure the fuse is intact ([E16224](#))
- Check to make sure that when a cycle is initiated, that there is 24V DC coming from the board to the clamp solenoid at terminals 11 & 12
 - ***** CAUTION: ONLY A QUALIFIED ELECTRICIAN SHOULD PERFORM THE FOLLOWING STEPS. POWER MUST BE SUPPLIED TO THE MACHINE TO CHECK THE CONTROL BOARD. THIS PRODUCES A SHOCKING HAZZARD. DO NOT TOUCH THE CONTROL BOX COMPONENTS WITH ANYTHING OTHER THAN ELECTIRCAL TESTING PROBES. *****
 - Run a cycle on the machine (put the stock in place, depress the safety buttons, and press the foot pedal), then check the pins at terminals 11 & 12, then the screws at 11 & 12
 - If there is no power at the pins, change the board ([E35424](#))
 - If there is power at the pins, but not at the screws, change the terminal strip ([E21016](#))

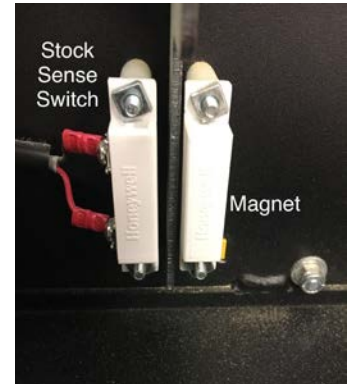



35.16 Test Stock Sense / Safety Blade Switch

- Disconnect power and air to the machine.
- Make sure the case top is shut.
- Locate pins "5" and "6" on the pin strip in the control box.
- Touch continuity tester to "5" and "6" on the pin strip.
- Continuity tester should read open.
- Press in safety buttons under the clamp guard and tester should read closed.

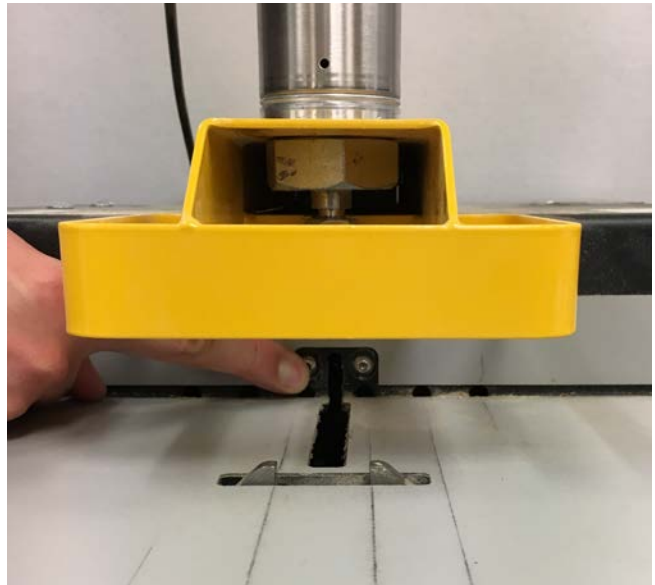
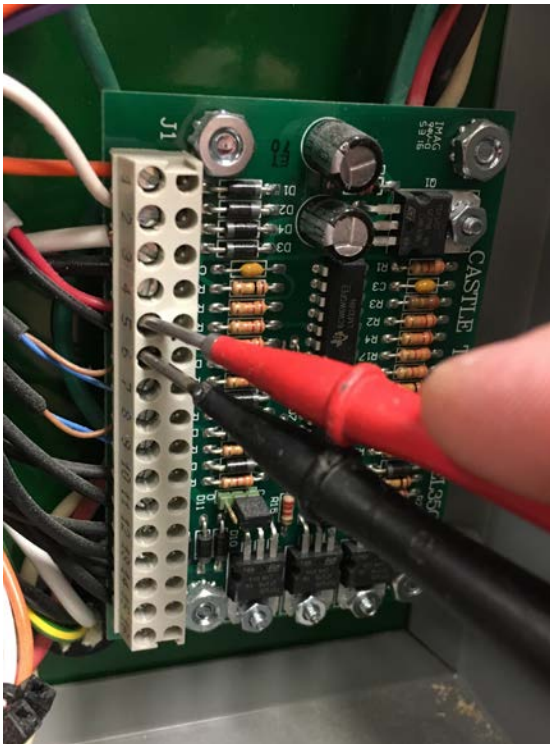



35.17 Test Foot Switch

- Disconnect air and power to the machine
- Locate pins "3" and "4" on the pin strip of the control board.
- Touch continuity tester pins to "3" and "4" on the pin strip and the switch should read open.
- Step on the foot peddle while still touching the pins and the continuity tester should read closed.

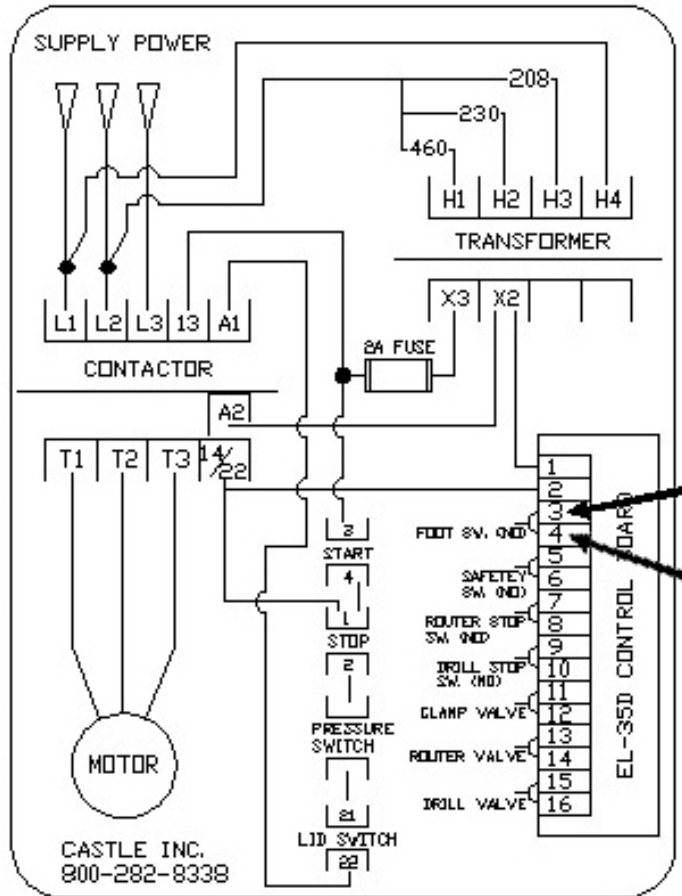
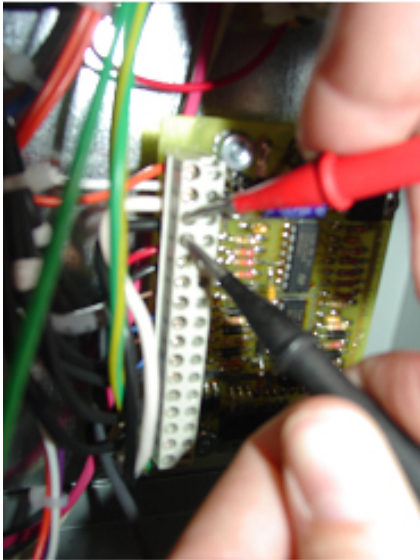



35.18 Machine starts, but shuts down when cycle is initiated:

!***ALWAYS DISCONNECT POWER AND AIR WHEN CHECKING SWITCHES ***!

- *Check the air pressure switch. Most common reason. ([E35420](#)) (See 35.14)*
 - The air pressure switch is set at 40 psi at the factory. It can often go bad and be hard to diagnose.
 - The easiest way to check is to bridge the two wires and see if the machine will turn on.
 - We no longer use the air pressure switch. Customers can keep the bridge in place if they do not wish to replace.



-
- *Check the overload ([E91827](#) 480V Overload / [E94060](#) 230V Overload / [E94061](#) Single phase overload)*
 - Increase the amperage capacity on the overload.
 - If this does not solve the issue, then most likely the problem is with the contactor or overload.
 - It is recommended to change both components. Currently the Sprecher & Schuh (S & S) brand we use will need both pieces to be changed, regardless if there is an old S & S in the machine. The new revision will not work with the old. ([E91024](#) – Contactor)
 - **** Contactors and overload components from different manufacturers **cannot** be combined. ****



35.19 No cycle - Clamp begins to come down, and immediately goes back up (flutters):

- Change the drill stop switch ([E35010](#)/ [E35009](#) – Strap)
 - This is the most common reason

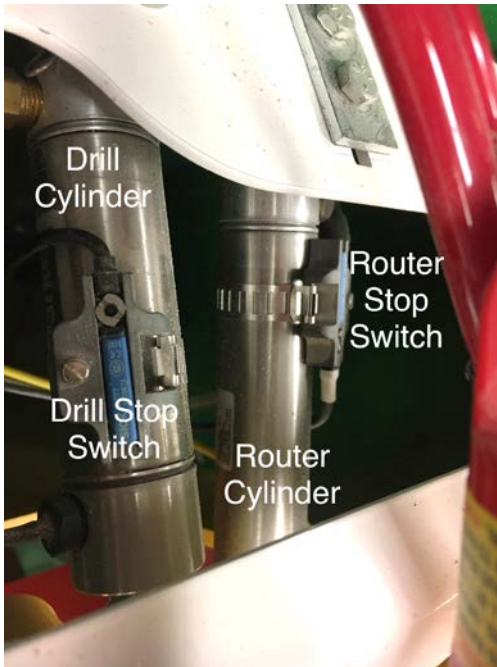



35.20 Clamp does not come down, but router and drill cycle:

!***ALWAYS DISCONNECT POWER WHEN CHECKING SOLENOIDS ***!

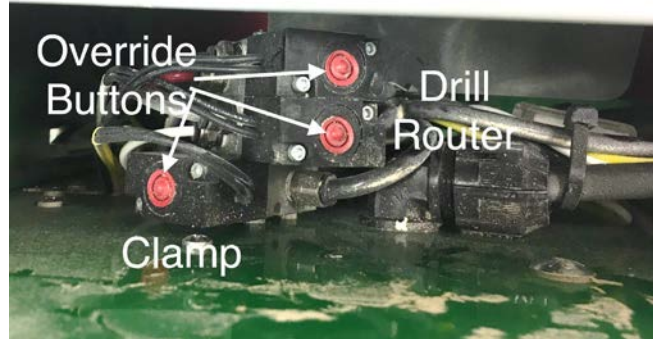

- Check the clamp solenoid ([P21224](#)) – first of the stack. The solenoids are located inside the case of the machine, behind the control box.
 - Press the red manual override button
 - Listen for air leaks and look for loose hose
 - If the clamp goes down, change the solenoid ([P21224](#)) – it is not working electrically
 - If the clamp does not go down, remove the hose from the top of the clamp and override again. (It is a push in fitting, hold the plastic ring at the end of the fitting down to the fitting, and pull out the hose. When replacing the hose, push hose in firmly – no need to hold the ring.)
 - If there is air out of the hose, change the clamp cylinder ([P00215](#))
 - If there is no air coming out of the hose, change the clamp solenoid ([P21224](#))

Push in Fitting Example





35.21 Clamp comes down, no router cycle, clamp does not retract:

- Run a dry cycle – put a piece of material next to, but not covering the router slot. Run a cycle.
 - If the clamp comes down and the router bit moves forward at normal speed
 - Check to make sure the router bit is spinning (and in the proper direction). If the belt ([H12075](#)) is broken or the spindle ([C35003](#)) not spinning, then the bit cannot move through the material to cut the pocket.
 - If the clamp comes down, but the router bit does not move:
 - Check the router feed rate valve ([P00117](#))
 - See if the valve has been turned all the way down
 - The valve will usually fail completely open, but can get plugged with debris on rare occasions.

!***ALWAYS DISCONNECT POWER WHEN CHECKING SOLENOIDS ***!

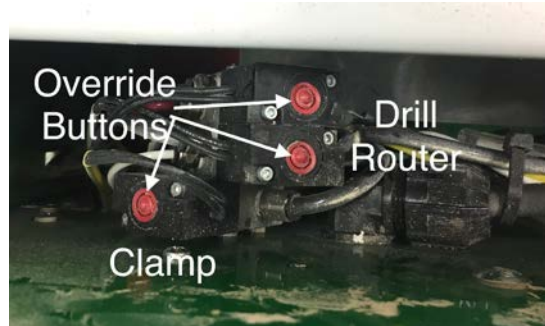

- Check the router solenoid ([P49410](#)) – middle of the stack. The solenoids are located inside the case of the machine, behind the control box.
 - Press the red manual override button.
 - If the router comes up with force when the override is pressed, but does not move when in cycle
 - Change the solenoid ([P49410](#)). There is a problem with the electrical portion of the valve.
 - If the router begins to move very slowly
 - Adjust the router feed rate to see if there is any change.
 - Listen for air leaks at the solenoid. If there is a continual air leak as the solenoid override is held down press a finger over the exhaust port.
 - If the carriage begins to move forward, change the solenoid ([P49410](#))
 - If the carriage does not move the router cylinder needs to be replaced ([P35300](#) / or [C35021](#)– complete cylinder assembly)
 - Remove the muffler / breather at the exhaust port and override. If the router moves with force, clean or change the muffler / breather ([P00018](#)).

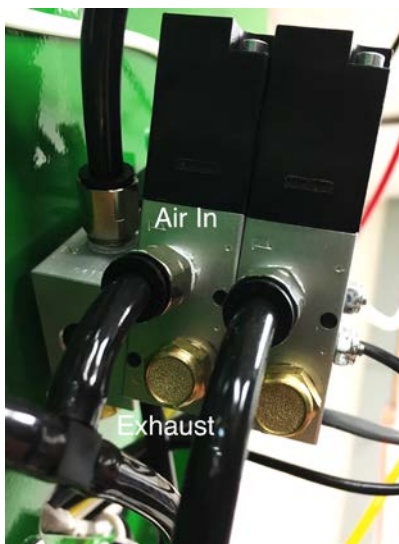



TSM-35 Screw Pocket Machine Troubleshooting

- If no air leaks, change the solenoid. ([P49410](#))
- If the router does not move when the override button is pushed, check to make sure air is coming out of the solenoid:
 - Remove the air line from port #4 (air out to router feed rate valve) and override.
 - If no air – replace the solenoid ([P49410](#))
 - If air, reinsert the air line in fitting
 - Remove air line from the top of the router feed rate valve and override
 - If no air – replace the hose between the solenoid and router feed rate valve ([P35018](#))
 - If air, reinsert the air line on fitting
 - Remove the air line from the bottom of the router feed rate valve and override
 - If no air – replace the router feed rate valve and fittings ([P00117](#) & [P18165](#) x2)
 - If air, reinsert the air line on fitting
 - Remove the air line from the bottom (operator end) of the router cylinder and override
 - If no air – replace the air line between the router feed rate valve and the cylinder ([P16181](#))
 - If air – replace the router cylinder ([P35300](#) / or [C35021](#) assembly)





35.22 Clamp comes down, pocket routes, no pilot hole, clamp stays down:

- Run a dry cycle – put a piece of material next to, but not covering the router slot. Run a cycle.
 - If the clamp comes down and the router bit goes up and stays in place until the machine is turned off, then it retracts
 - Check the router stop switch for position on the cylinder - move slightly toward the operator
 - Change the router stop switch. ([E35010](#)/ [E35009](#) – Strap)
 - If the clamp comes down, the router bit comes up, and the router stays up after the machine is turned off

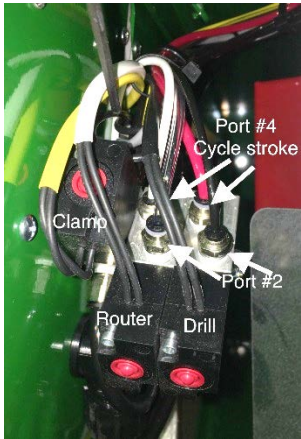

- Disconnect main air
- If router retracts, change router solenoid ([P49410](#))
- If router does not retract even after air has been disconnected, remove and clean the muffler/breather on the router solenoid ([P00018](#))
- Check for a crimped air line

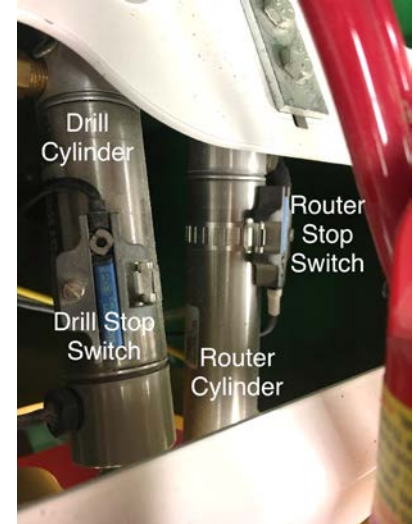

- If the clamp comes down, the router moves slowly, and then the drill runs at speed:
 - Check the router solenoid ([P49410](#)) and router cylinder ([P35300](#))

!***ALWAYS DISCONNECT POWER WHEN CHECKING SOLENOIDS ***!

- Override the router solenoid (middle of the stack) with the red button
 - Make sure the router feed rate valve has not been turned down
 - Listen for air leaks at the solenoid. If there is a continual air leak as the solenoid override is held down press a finger over the exhaust port.
 - If the carriage begins to move forward, change the solenoid ([P49410](#))
 - If the carriage does not move the router cylinder needs to be replaced ([P35300](#) / or [C35021](#) – complete cylinder assembly)
 - If there is no leak and the router moves forward slowly remove the muffler / breather ([P00018](#)) and override again. If it still moves slowly, replace the solenoid ([P49410](#)).



TSM-35 Screw Pocket Machine Troubleshooting

- *If the clamp comes down, the router moves normally, and the drill does not move forward or begin to spin:*
 - Override the drill solenoid (last of stack) with red button
 - *If the carriage does not move, and the drill does not spin, remove the air line at port #4 on the solenoid and override again*
 - If no air blows out of the port, replace the drill solenoid ([P49410](#))
 - If air comes out of the solenoid port, check for clogs in the air line to the cylinder and the drill delay assembly.
 - If no clogs, change the drill solenoid ([P49410](#)). It is not working electrically.
- *If the clamp comes down, the router moves normally, the drill does not move forward but begins to spin:*
 - Check the drill feed rate valve to make sure it is not turned all the way down

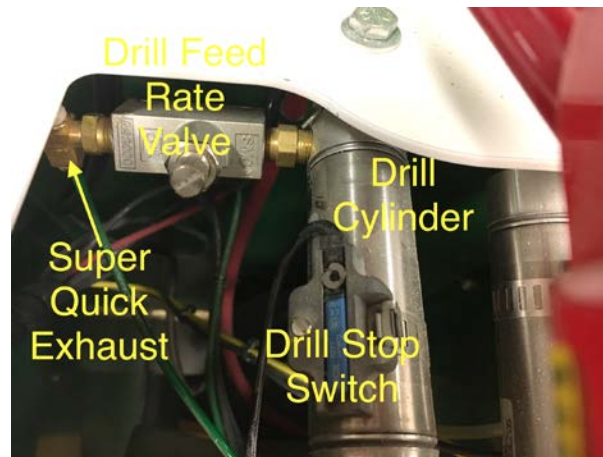
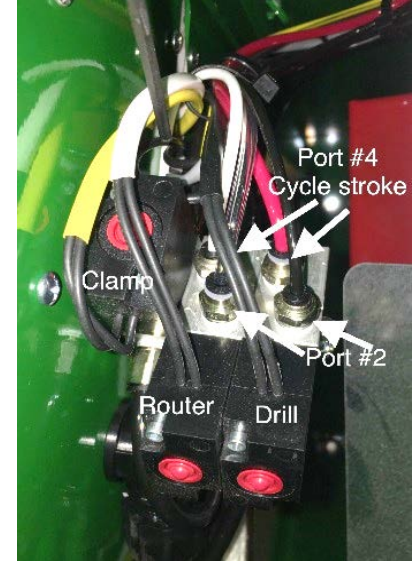

- Override the drill solenoid (last in stack) with red button
 - Listen and feel for air leaks at the super quick exhaust
 - If there is an air leak with the override button depressed, change the SQE ([P10320](#))
 - If there is an air leak at the SQE when the override button is NOT depressed, change the drill cylinder ([P35125](#) / or [C35022](#) complete drill cylinder assembly)
- Remove the air line to the super quick exhaust on the drill feed rate valve and override the drill solenoid
 - If no air from the line, check the air line for clogs
 - If air from the line, change the drill cylinder
- *If the clamp comes down, the router and drill cycles both run at speed and the drill is spinning:*
 - Check the router solenoid ([P49410](#)) and router cylinder ([P35300](#))



TSM-35 Screw Pocket Machine Troubleshooting

- Override the router solenoid (middle of the stack) with the red button
 - Listen for air leaks at the solenoid. If there is a continual air leak as the solenoid override is held down, press a finger over the exhaust port.
 - If the carriage begins to move forward, change the solenoid ([P49410](#))
 - If the carriage does not move the router cylinder needs to be replaced ([P35300](#) / or [C35021](#) – complete cylinder assembly)
 - Remove the muffler / breather ([P00018](#)) at the exhaust port on the router solenoid and run a pocket. If the cycle completes, change or clean the muffler / breather.
- Check the drill solenoid ([P49410](#))
 - Override the drill solenoid (last of the stack) with the red button and try to stop the carriage from moving forward

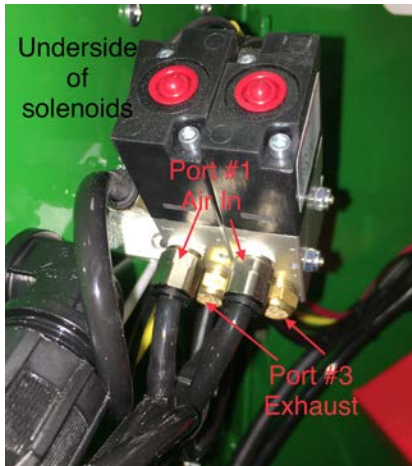

- If you can stop the carriage:
 - Listen / feel for air leaks at the muffler breather on the drill solenoid
 - If there is a constant leak when trying to stop the carriage, replace the drill cylinder ([P35125](#))
 - If there is a constant leak when the machine is at rest, change the drill solenoid ([P49410](#))
 - Listen / feel for air leaks at the super quick exhaust (SQE) ([P10320](#)) on the drill feed rate assembly.
 - If there is a constant leak without overriding the solenoid, replace the drill cylinder ([P35125](#))
 - If there is a constant leak when the drill solenoid is overridden, replace the SQE ([P10320](#))
 - If there are no air leaks, replace the drill solenoid ([P49410](#))
- Check the drill ([P01957](#)) (**See 35.23**)



35.23 – Checking the Drill Motor for function

!NOTE: The drill should have a visible slick of oil and sawdust mix at the front vent area. If not, this indicates a drill that is not receiving lubrication and will most likely need to be replaced.



- Run a dry cycle – put a piece of material next to, but not covering the router slot. Run a cycle.
- *If the clamp comes down, the router moves forward normally, the drill carriage comes forward, but the drill does not begin to spin:*
 - Remove the small red or black hose (air in from solenoid) from the drill delay assembly and override the drill solenoid (last in stack) ***** CAUTION – the drill carriage will move forward when overriding the solenoid *****
 - If no air comes out of the small red or black hose AND the drill carriage comes forward, check for a blockage in the red hose. (There is a T Barb fitting in this hose.)
 - If air comes out of the red hose:
 - Replace the red hose and override the solenoid - listen for air blowing through the drill
 - If there is air blowing through the drill, but it is not spinning, replace the drill ([P01957](#))
 - If there is no air blowing through the drill when the solenoid is overridden:
 - Remove the drill from the drill carriage by removing the carriage bolts that hold the drill mounting plate to the yellow carriage (mark drill height before removing).
 - Then remove the drill from the brass fitting that connects it to the pilot valve and drill delay assembly.
 - Override the drill solenoid (last one in the stack) and see if air blows out of the brass fitting. **** Caution: the drill carriage will move forward when overriding the solenoid. ****
 - *If no air comes out of the fitting from the pilot valve / hose assembly:*
 - Remove the small red or black hose (air in from solenoid) from the push in fitting on the drill delay assembly and override again.
 - If air comes out of the small hose, replace the pilot valve ([P35250](#))





TSM-35 Screw Pocket Machine Troubleshooting

- **** Drain the air tank with the drain cock prior to working on the pilot valve. We recommend purging the air lines and tank to remove as much debris as possible.
- To confirm that there is air reaching the pilot valve:
 - Remove main air from machine
 - Use the drain cock to drain the air tank
 - Remove the pilot valve from the large red hose that supplies air from the air tank
 - Place a towel over the fitting on the red hose and reattach main air to the machine ****CAUTION – air and air tool oil should immediately blow from the red hose, make sure the hose is secure when main air is reattached.**
 - If air does blow from the hose, the pilot valve needs to be replaced.
 - If there is no air out of the hose, then the issue is with the air supply to/from the air tank. Check the lubricator to make sure it is providing air, check the check valve to make sure it is allowing air through, check to make sure the air tank is able to hold air and deliver air, check the red hose from the tank to make sure it is not blocked.
- *If air comes out of the fitting from the pilot valve / hose assembly:*
 - Place a towel over the fitting and override the solenoid again. Look for debris and or air tool oil on the towel.
 - If there is visible debris:
 - Replace the pilot valve ([P35250](#))
 - Check the screen in the back of the air drill. If there is visible debris, replace the air drill ([P01957](#))
 - **** Drain the air tank with the drain cock prior to working on the pilot valve. We recommend purging the air lines and tank to remove as much debris as possible.





TSM-35 Screw Pocket Machine Troubleshooting



- If there is no debris and no air tool oil on the towel:
 - !*** **NOTE: The air drill must receive lubrication. If it does not, it can become charred on the inside and must be replaced. (P01957)**
 - Check the lubricator on the front of the machine. If it does not have oil in the reservoir, add oil and override the solenoid multiple times to help prime the system.
 - If there is oil in the reservoir, override the solenoid to and check the top of the lubricator to see if drips of oil are falling while the solenoid is depressed. Try to turn up the lubricator feed rate to a drop every few seconds.
 - If the lubricator will not turn up, replace the lubricator – check for brand.
 - Clippard ([P35081](#))
 - Parker ([P35067](#))
 - Watts – Need to replace both units ([C35002](#))
 - If the drill has stopped spinning due to lack of oil, it will need to be replaced. ([P01957](#))
- If there is oil on the towel but no debris
 - Replace the drill ([P01957](#))
- *If the drill spins while moving forward, but bogs down when trying to drill the pilot hole:*
 - Begin with the test information above. If the issue is not discovered with the above diagnostics:
 - Remove the drill from the drill carriage by removing the carriage bolts that hold the drill mounting plate to the yellow carriage (mark drill height before removing).
 - Then remove the drill from the brass fitting that connects it to the pilot valve and drill delay assembly.
 - Use air from a secondary source into the air drill
 - Try to use the drill as a hand tool to drill into material. If it bogs down, it will need to be replaced. ([P01957](#))
 - If the drill did not bog down outside the machine, reinstall the drill on the fitting of the pilot valve assembly. Override the drill solenoid and use the drill as a hand tool to see if the bit bogs down. If the drill slows down or stops, replace the pilot valve ([P35250](#))
 - If the drill does not bog down in either test, check the drill solenoid ([P49410](#))
 - Override the drill solenoid (last of the stack) with the red button and try to stop the carriage from moving forward



TSM-35 Screw Pocket Machine Troubleshooting

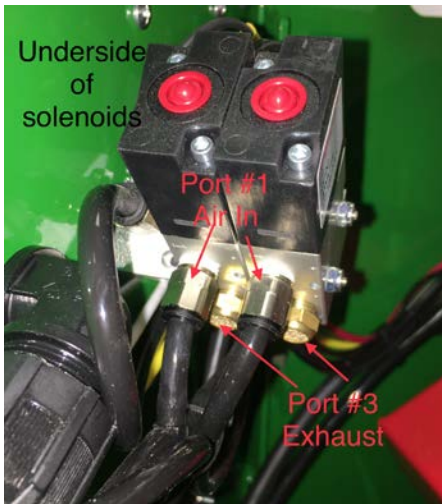

- If you can stop the carriage:
 - Listen / feel for air leaks at the muffler breather on the drill solenoid
 - If there is a constant leak when trying to stop the carriage, replace the drill cylinder ([P35125](#))
 - If there is a constant leak when the machine is at rest, change the drill solenoid ([P49410](#))
 - Listen / feel for air leaks at the super quick exhaust (SQE) ([P10320](#)) on the drill feed rate assembly.
 - If there is a constant leak without overriding the solenoid, replace the drill cylinder ([P35125](#))
 - If there is a constant leak when the drill solenoid is overridden, replace the SQE ([P10320](#))
 - If there are no air leaks, replace the drill solenoid ([P49410](#))



35.24 – The clamp comes down, the router cuts a pocket, the drill makes a pilot hole, but the clamp does not release:

- Run a dry cycle – put a piece of material next to, but not covering the router slot. Run a cycle.
 - If the clamp comes down, the router comes up and retracts, and the drill comes forward but does not retract, and the clamp stays down:
 - Check the drill stop switch for position on the cylinder - move slightly toward the back of the machine
 - Change the drill stop switch ([E35010](#)/ [E35009](#)– Strap)
 - This is the most common reason for the drill to stay forward
 - If the drill retracts but the clamp stays down
 - Check the muffler / breather ([P00018](#)) on the clamp solenoid
 - Remove the breather and run a cycle
 - If the cycle completes, clean or replace the breather
 - With the clamp cylinder retracted, override the clamp solenoid ([P21224](#)) – first solenoid in the stack.
 - If the clamp extends when the solenoid is overridden AND retracts when the override is released, replace the solenoid ([P21224](#))
 - If the cycle completes in dry cycle, but not when cutting a pocket in material:
 - Check the drill solenoid ([P49410](#))
 - *** DISCONNECT POWER WHEN CHECKING SOLENOIDS ***
 - Override the drill solenoid (last of the stack) with the red button and try to stop the carriage from moving forward
 - If you can stop the carriage:

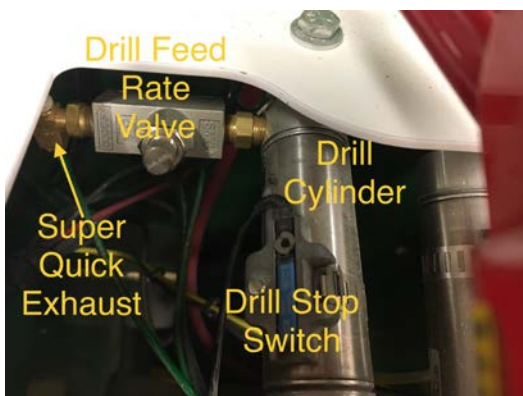

- Listen / feel for air leaks at the super quick exhaust (SQE) on the drill feed rate assembly.
 - If there is a constant leak without overriding the solenoid, replace the drill cylinder ([P35125](#) / or [C35022](#) complete drill cylinder assembly)
 - If there is a constant leak when the drill solenoid is overridden, replace the SQE ([P10320](#))
- Listen / feel for air leaks at the muffler breather
 - If there is a constant leak when the solenoid is overridden, change the drill cylinder ([P35125](#) / or [C35022](#) complete drill cylinder assembly)
- If there are no air leaks, replace the drill solenoid ([P49410](#))
- Check the drill (P01957) (**See 35.23**)



35.25 – The machine clamps, routes, drills, unclamps but the bit is stuck in the material:

- *If the drill retracts once it is removed from the material:*
 - Adjust the drill delay to spin longer once the drill begins to retract
 - Adjust the drill delay (turn clockwise) and override the drill solenoid using the red override button. (The drill solenoid is the last in the stack.)
 - When you release the override button, the drill should continue to spin for a few moments. Adjust so that the drill continues to spin until it is over halfway through its retraction. Run a pocket in material, and confirm that the drill will not stick.
 - If the drill delay valve does not change the amount of time the drill spins after the solenoid override button is released – the drill either stops spinning immediately when air is stopped, or never stops spinning when air is stopped:
 - Replace the drill delay valve ([P00117](#)) or the drill delay assembly ([C35005](#))
- *If the drill stays out after it is removed from the material and the power is off – disconnect main air:*
 - If drill retracts, change drill solenoid ([P49410](#))
 - If drill does not retract even after air has been disconnected, change the super quick exhaust on the drill feed rate valve assembly ([P10320](#)) and remove and clean the muffler/breather on the drill solenoid ([P00018](#))

